

MISUTONIDA

italian style accessories **4x4**

SUZUKI GRAND VITARA 05/06 5 DOORS



Item Code

Codice Articolo

Référence Article

: **GP/168/IX**
GPO/168/IX
DSP/168/IX

GB

STAINLESS STEEL GRAND PEDANA/
OVAL GRAND PEDANA/DESIGN SIDE PROTECTION

ITA











GRAND PEDANA/GRAND PEDANA OVALE/
PROTEZIONE LATERALE DESIGN IN ACCIAIO
INOX

FR

GRAND PEDANA/GRAND PEDANA OVALE/
PROTECTION LATERALE DESIGN EN ACCIER
INOX

SUZUKI GRAND VITARA 05/06

5 DOORS

Part List Lista della bulloneria Liste des pièces	
A  TE 10X50 Black Nero Noir x 4	I  S/168/A-SX x 1
B  M10 autoblocking autobloccante autobloquant x 4	L  Distance piece 20x20 Distanziale 20x20 Entretoise 20x20 x 1
C  TE 8X25 x 12	
D  Ø 8 x 12	
E  Ø 8 x 12	
F  S/168/P-SX x 1	
G  S/168/P-DX x 1	
H  S/168/A-DX x 1	

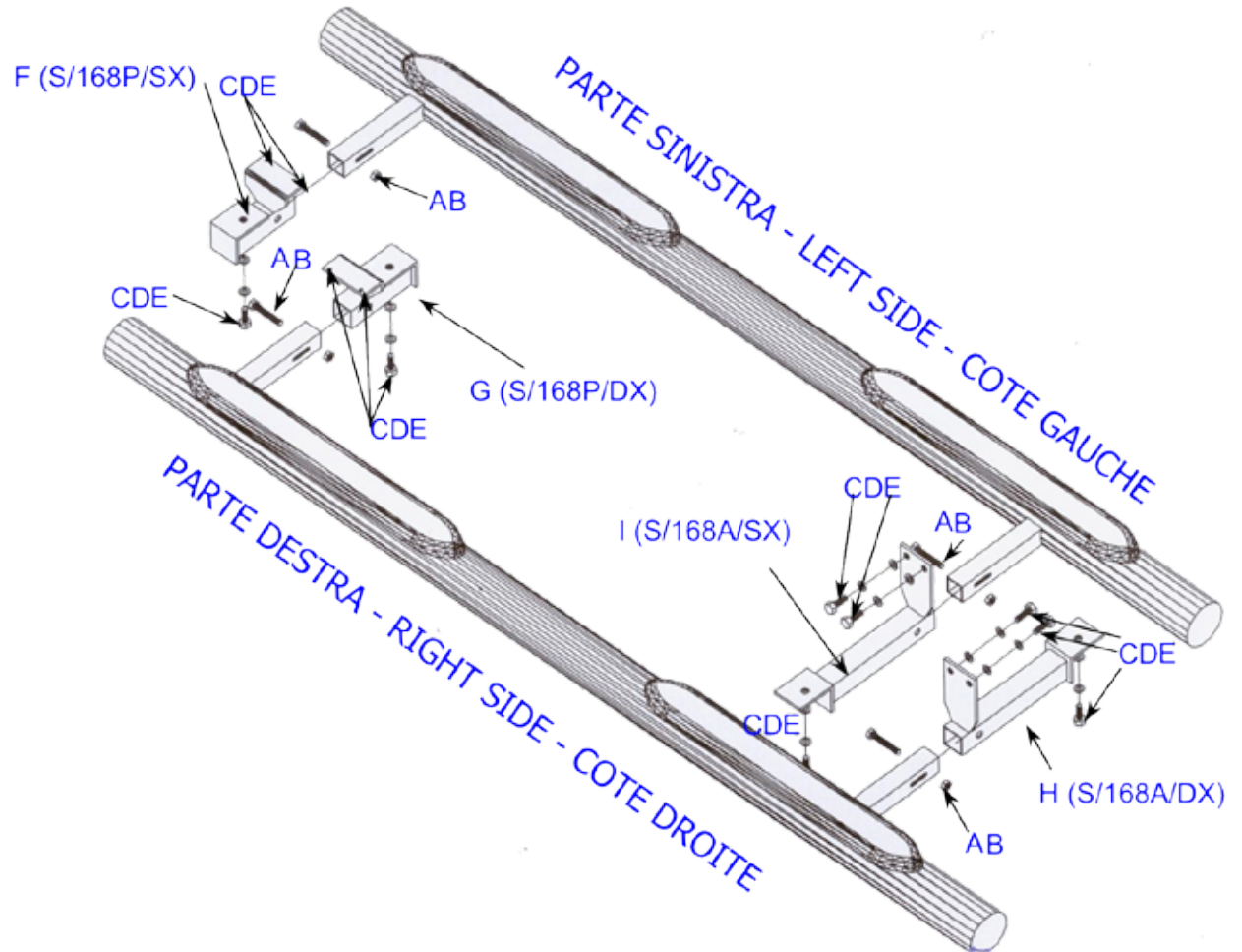

MISUTONIDA
italian style accessories **4x4**

GB

**FITTING
INSTRUCTIONS
FRONT SIDE**

1. Position the H,I brackets in correspondence to the threaded holes already present on the front part bodywork (picture 1)

REAR SIDE

2. Unscrew the bracket that holds the pipes located in the rear left side

3. Position the F and G brackets in correspondence of the threaded holes already present on the bodywork in the rear side (picture 2)

4. Assemble the grand pedana by positioning the brackets at the desired distance and tighten all the bolts.

5. Continue to tighten all the bolts and insert between the brackets that holds the pipes and the body work the L distance piece (pictures 3 and 4).

ITA

**ISTRUZIONI DI
MONTAGGIO
PARTE ANTERIORE**

1. Posizionare le staffe H e I in corrispondenza dei fori filettati esistenti sul telaio nella parte anteriore (foto 1)

PARTE POSTERIORE

2. Svitare la staffa che sorregge i tubi situati nella parte posteriore sinistra.

3. Posizionare le staffe F e G in corrispondenza dei fori filettati esistenti sul telaio nella parte posteriore (foto 2)

4. Montare la grand pedana posizionando le staffe alla distanza desiderata e serrare tutta la bulloneria.

5. Procedere al serraggio di tutti i bulloni inserendo il distanziale L tra la staffa che sorregge i tubi ed il telaio (foto 3 e 4).

FR

**INSTRUCTIONS DE
MONTAGE
PARTIE ANTERIEURE**

1. *Positionner les étriers H et I en correspondance des trous filetés déjà présents sûr le châssis dans la partie antérieure (photo 1)*

PARTIE POSTERIEURE

2. *Devisser l'étrier qui soutient les tubes positionnés dans la partie postérieure gauche.*

3. *Positionner ls étriers F et G en correspondance des trous filetés déjà présents sûr le châssis dans la partie postérieure (photo 2)*

4. *Monter le grand pedana en positionnant les étriers à la distance désirée et serrer toute la boulonnerie.*

5. *Continuer à serrer toute la boulonnerie en insérant l'entretoise L entre l'étrier qui soutient les tubes et le châssis (photos 3 et 4).*



Date Data Date	Item Code Cod.Articolo Réf. Article	Vehicle model Modello Veicolo Modèle de Voiture
08/03/06	GP/168/IX GPO/168/IX DSP/168/IX	SUZUKI GRAND VITARA 05/06 5 doors

Checked and approved by
Controllato ed approvato da
Controlé et approuvé par

**Claudio
Gallo**

 **MISUTONIDA**
italian style accessories **4x4**