

MISUTONIDA

italian style accessories **4x4**

SUBARU TRIBECA



Item Code

: GP/201/IX

Codice Articolo

GPO/201/IX

Référence Article

DSP/201/IX

GB

STAINLESS STEEL GRAND PEDANA/OVAL GRAND
PEDANA/DESIGN SIDE PROTECTION

ITA











GRAND PEDANA/GRAND PEDANA OVALE/
PROTEZIONE LATERALE DESIGN IN ACCIAIO INOX

FR

GRAND PEDANA/ GRAND PEDANA OVALE/
PROTECTION LATERALE DESIGN EN ACCIER
INOX

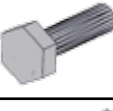
SUBARU TRIBECA

Part List
 Lista della bulloneria
 Liste des pièces

A	 T145 x 2	G	 Ø 12 x 2
B	 P/176/A x 2	H	 M 12 x 2
C	 Ø 8 x 10	I	 AB/201 x 2
D	 Ø 8 x 10	L	 TE 8X25 x 8
E	 M 8 x 10	M	 GP/201/C x 2
F	 Ø 12 x 2	N	 GP/201/D x 2

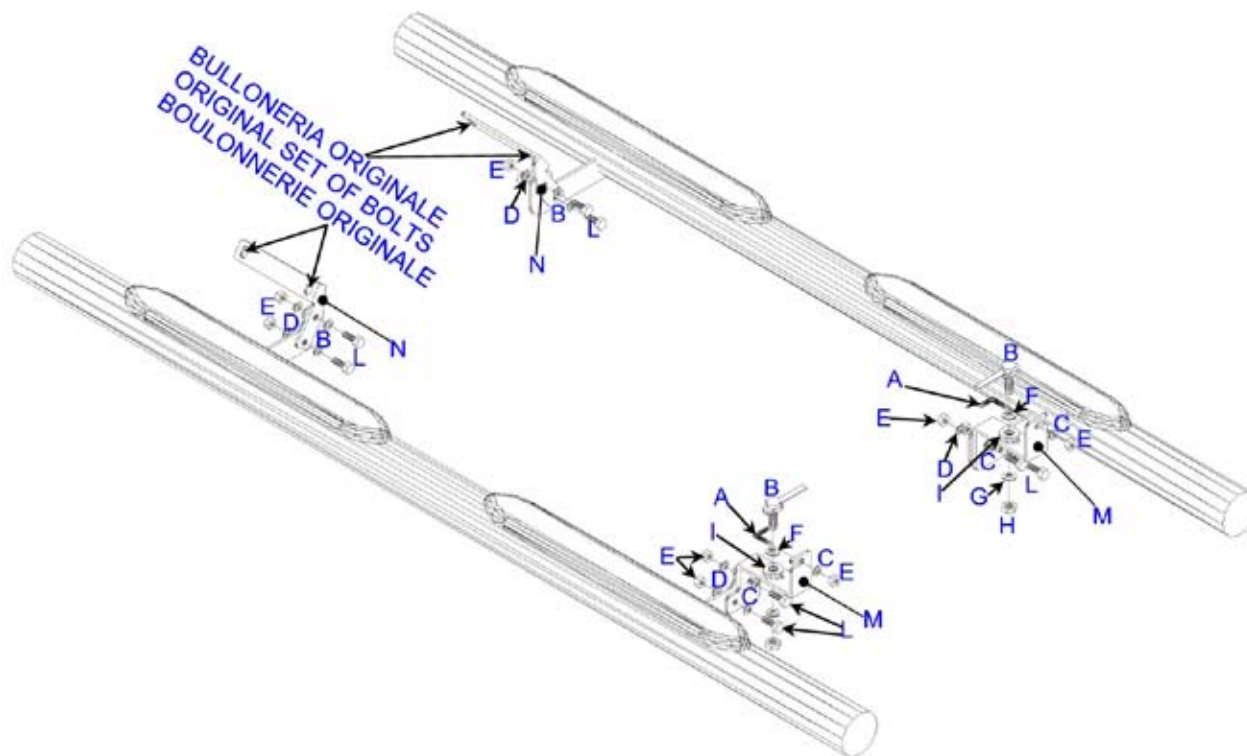

 **MISUTONIDA**
  *italian style* **4x4**
accessories

GB**FITTING
INSTRUCTIONS****FRONT SIDE**

1. Remove the n.2 plastic caps indicated in picture 1.
2. Insert A as indicated in picture 2.
3. Insert B as indicated in picture 3.
4. Position the M bracket as shown in picture 4 using C,D,E,F,G,H,I and tighten as indicated in picture 5.

REAR SIDE

5. Remove the n.2 bolts indicated in picture 6, position the N bracket in correspondence of the holes just freed and fix it with the original bolts (picture 7)
6. Fit the brackets welded to the accessory on M and N using C,D,E,L (pictures 8 and 9).
7. Tighten all the set of bolts.

ITA**ISTRUZIONI DI
MONTAGGIO****PARTE ANTERIORE**

1. Rimuovere i n.2 tappi in plastica indicati in foto 1.
2. Inserire A come indicato in foto 2.
3. Inserire B come indicato in foto 3.
4. Posizionare la staffa M come indicato in foto 4 utilizzando C,D,E,F,G,H,I e serrare come indicato in foto 5.

PARTE POSTERIORE

5. Rimuovere i n.2 TE indicati in foto 6, posizionare la staffa N in corrispondenza dei fori appena liberati e fissarla con i TE originali (foto 7).
6. Montare le staffe saldate all'accessorio su M e N utilizzando C,D,E,L come indicato nelle foto 8 e 9.
7. Serrare tutta la bulloneria.

FR**INSTRUCTIONS DE
MONTAGE****PARTIE ANTERIEURE**

1. Enlever les n.2 bouchons en plastique indiqués en photo 1.
2. Insérer A comme indiqué en photo 2.
3. Insérer B comme indiqué en photo 3.
4. Positionner l'étrier M comme indiqué en photo 4 en utilisant C,D,E,F,G,H,I et serrer comme indiqué en photo 5.

PARTIE POSTERIEURE

5. Enlever les n.2 boulons indiqués en photo 6, positionner l'étrier N en correspondance des trous précédemment libérés et le fixer avec les boulons originales (photo 7).
6. Monter les étriers soudés à l'accessoire sur M et N en utilisant C,D,E,L (photos 8 et 9)
7. Serrer toute la boulonnerie.

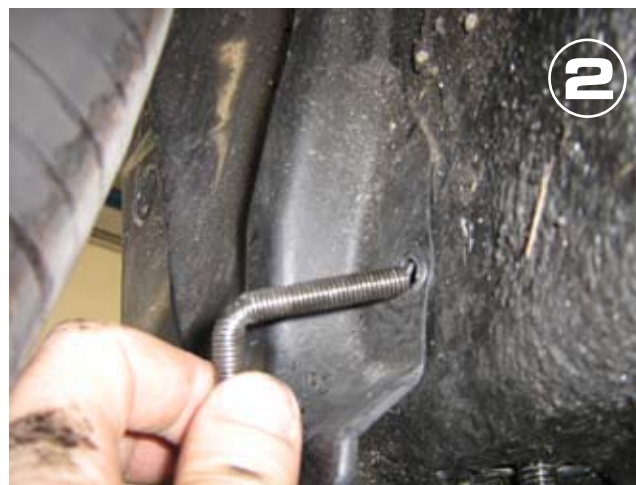



Date Data Date	Item Code Cod.Articolo Réf. Article	Vehicle model Modello Veicolo Modèle de Voiture
07/05/07	GP/201/IX GPO/201/IX DSP/201/IX	SUBARU TRIBECA

Checked and approved by
Controllato ed approvato da
Controlé et approuvé par

Botta
Pietro

MISUTONIDA
 italian style
 accessories **4x4**